

YANMAR SERVICE NEWS

Title	Cautions for Ordering Engine-mount Tachometer with Hour Meter (Rev. 1: Tachometer rev. direction ID code specified.)		No. :03-2-G-07-017-L-Rev.1 Date: Jan. 2004
	Eng. Model	ALL	Applications Marine main & aux.; Industrial engines Engine Nos. _____

Following failure concerning the engine-mount tachometer has been reported to us recently: For the purpose of replacing the conventional engine-mount tachometer with the tachometer having the hour meter, a user ordered the tachometer (clockwise revolving type, XR) from us since the engine revolutions were clockwise, (XR). After replacing the tachometer, however, the user found that while the tachometer reading was correct, the hour meter turned reverse. To correct this trouble, the user again procured the tachometer with the hour-meter, (counterclockwise revolving type, XL) from us for replacement. Upon installing this XL type tachometer, the hour-meter performed normally

1. Cause of Trouble

The directions of revolutions of tachometer, specified as Clockwise (XR) or Counterclockwise (XL), are the directions when the tachometer's drive shaft was seen from the drive side.

Please note that the tachometer's revolving direction specified in the Parts List is the revolving direction of the tachometer itself.

Example): The 6G-ST engines revolve clockwise (when viewed from the flywheel side).

When the tachometer is driven by the camshaft end at the flywheel side, the tachometer's revolving direction is clockwise. In this case, it is necessary to procure the counterclockwise revolving (viewed from the driven side of the drive shaft) type (XL) tachometer.

2. Caution

The revolving directions specified in the Parts List, XR or XL, are the directions when the tachometer's drive shaft was seen from the drive side. So, before ordering the tachometer from us, be sure to check the revolving direction of the engine's shaft for driving the tachometer and specify which of the clockwise or counterclockwise type is necessary.

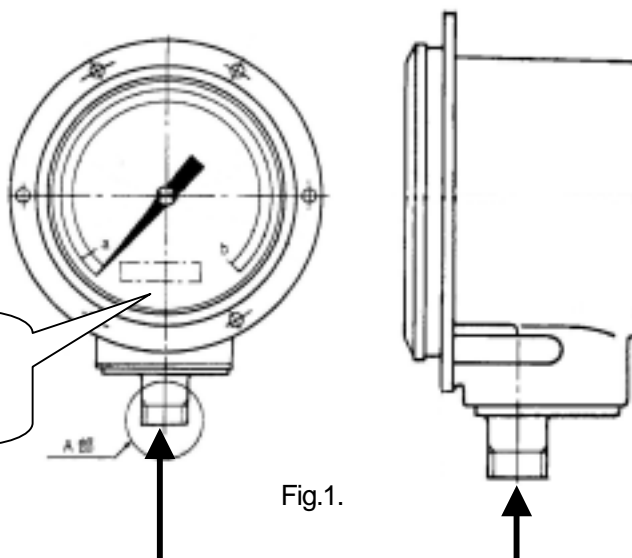

Fig.1.

The tachometer's drive shaft revolving direction viewed from this side is specified in the Parts Catalog.

YANMAR CO.,LTD. ENGINE PRODUCT OPERATIONS DIV. LARGE ENGINES FACTORY QUALITY ASSURANCE DEPT. FAX.No.: +81-6-6488-4003	Approved	Checked	Drawing
	<i>K. Ueda</i>	<i>T. Takahashi</i>	<i>G. Matsunaga</i>